



A12AQ - AEC-Q100 Qualified SoC for Automotive Cameras

Overview

The AEC-Q100-qualified A12AQ SoC family provides an integrated single-chip solution for single-channel electronic mirrors and single / dual sensor video recording systems. The A12AQ's combination of advanced image processing, high dynamic range (HDR), 3D noise filtering, smart auto exposure (AE), and high-resolution capability provide superior visibility even in low light or high contrast scenes. The chip also supports wide-angle and fish-eye lens by performing distortion correction via dedicated hardware blocks.

The SoC implements a highly-optimized hardware H.264 encoder that enables digital video recording systems with streaming capability over WiFi and 4G LTE. The flexible video capture allows connection of two image sensors with independent resolutions and independent controls. The dual-channel video processing removes the need for a dedicated ISP chip in every camera module, enabling compact camera modules while improving video quality, reducing power consumption, and lowering system cost.

A12AQ is an ideal solution for single-channel mirror solutions that require a secondary analog / digital input from a backup camera to support picture-in-picture (PIP) and video recording or streaming capability. It also supports frame rate conversion to maintain a constant output frame rate while dropping the input frame rate to maintain image fidelity in low light scenes.

The SoC includes a high speed 552 MHz single core Arm[®] Cortex[®]-A9 CPU with Neon DSP extensions to enable powerful processing performance for customer applications including the user interface and wireless networking. The flexibility of the firmware / hardware also allows implementation of proprietary communication protocols along with targeted and non-targeted auto-calibration solutions.

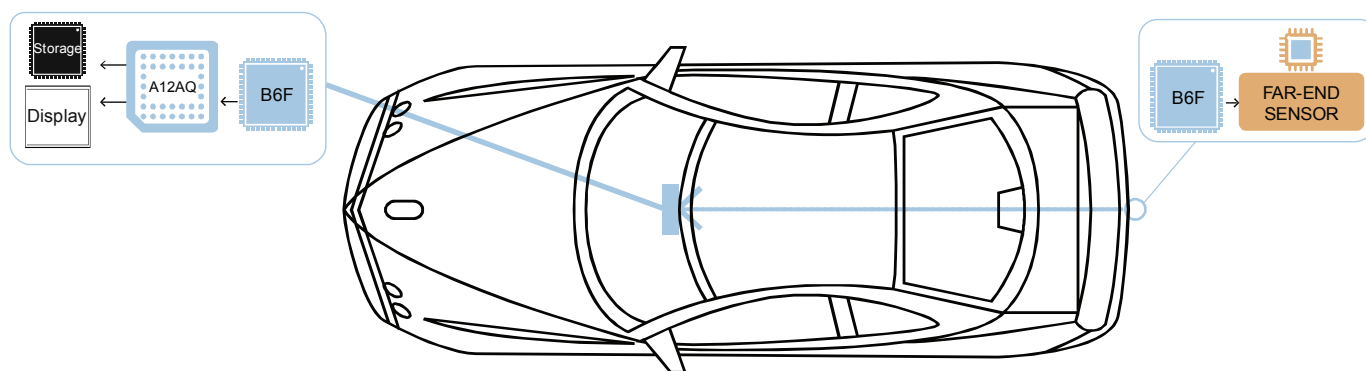

Example of A12AQ-based Single Channel eMirror System

Block Diagram

The illustration provided below is a block diagram of the A12AQ SoC.

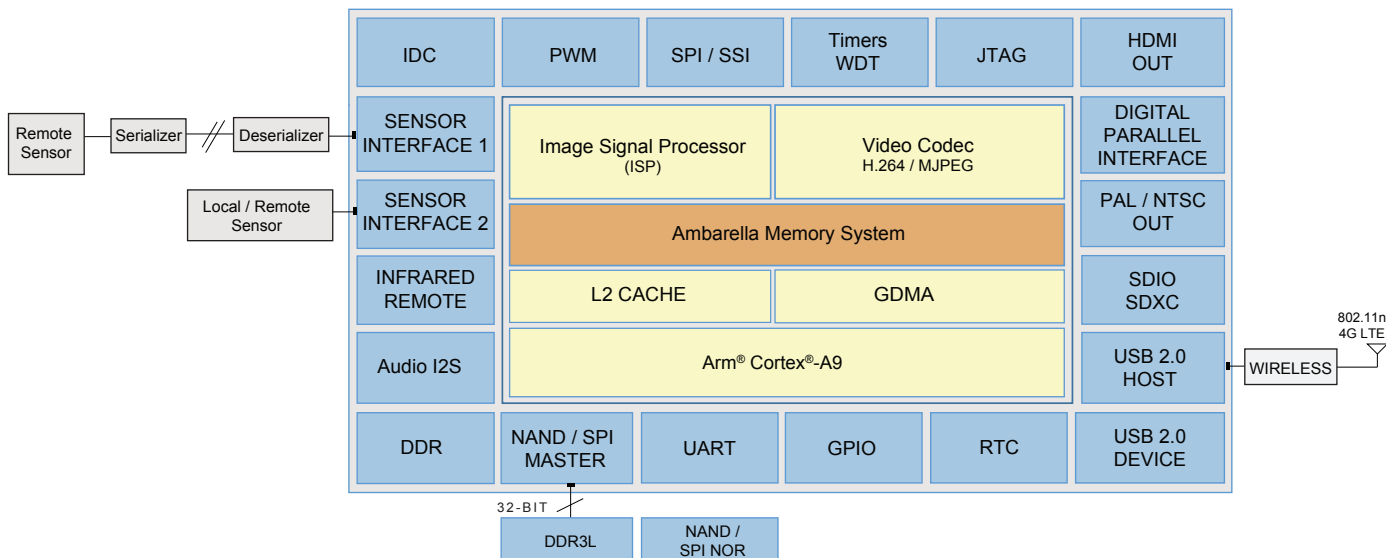

Key Features

Superior Image Quality

- Advanced night vision for low light conditions using smart exposure and temporal noise filtering
- Wide dynamic range (WDR) and high dynamic range (HDR)
- Automotive multi-channel smart auto exposure (AE) and auto white balance (AWB)

Advanced Features

- Multiple hardware and software fail-safe mechanisms to prevent “frozen image” errors
- WiFi and 4G LTE connectivity

General Specifications

Video Input

- SLVS, MIPI CSI-2, LVCMOS, 16-bit parallel interface
- CCIR.601 video input with external sync signals and BT.1120 / CCIR.656 style with embedded sync codes

Video Output

- Analog: On-chip video DAC for 480i / 576i composite NTSC / PAL output
- 16-bit parallel output supporting RGB and YUV formats with embedded and external syncs
- HDMI 1.4b output with CEC and on-chip PHY

Powerful CPU for Advanced Driver Assistance

- Single core Arm® Cortex®-A9 @ up to 552 MHz
- 32 KB / 32 KB I/D and 128 KB L2 Cache
- AES / 3DES / SHA-1 / MD5 cryptography engine

Recording File Formats

- Audio: AAC (Two-channel LC, HEAAC, HEAAC v2), ADPCM / LPCM / PCM
- Video File: MP4, MOV, AVI, TS
- Photo File: JPG

Peripheral Interfaces

- Two USB 2.0 ports, 1 USB 2.0 host, and 1 USB 2.0 host / device
- Ethernet MAC with IEEE 802.3-compliant RMII / MII Gigabit (10 / 100-Mbps) interfaces
- Multiple I2S, SSI / SPI, IDC, and UART
- Multiple GPIO ports, PWMs, steppers, IR, and ADC channels
- Watchdog timer, multiple general purpose timers, JTAG

High-Performance Automotive Video Engine

- Simultaneous encode of multiple high-resolution streams in multi-camera systems
- Night vision with super-resolution oversampling, 3D noise filters, and dynamic tone mapping
- Real time geometric distortion correction (de-warp) filter
- Advanced automotive dynamic range (HDR / WDR) engine with local exposure, highlight, and tone adjustment
- Multi-channel automotive smart auto exposure with scene detection, object detection, and dynamic AE
- Picture-in-picture support for dual channel electronic mirrors
- Frame rate conversion to maintain constant output frame rate during low light conditions

Advanced Video and Display Processing

- MP H.264 level 5.1 and MJPEG encode
- LCD rotation with crop, mirror, flip, and scale functions
- Alpha-blending OSD

Memory Interfaces

- LPDDR3, DDR3, and DDR3L up to 432 MHz
- 16-bit / 32-bit data bus, up to 2 GB capacity
- Two SD controllers with SDXC™ SD™ card support; one port supports up to UHS-1 speed
- Parallel NAND flash with ECC
- Boot from SPI NOR / NAND flash / USB / eMMC

Physical

- 28 nm low power CMOS
- AEC-Q100 grade 2 (-40°C to +105°C) operating temperature range
- LFBGA package with 404 balls, 15x15 mm, 0.65 mm pitch

A12AQ Advanced HD Automotive Camera Development Platform

The A12AQ automotive camera development platform contains the necessary tools, software, hardware, and documentation to develop a fully featured automotive camera system.

Evaluation Kit (EVK)

- A12AQ main board with connectors for sensor / lens board, peripherals
- Camera modules or sensor boards: OmniVision, ON Semiconductor, Sony, and others
- Datasheet, BOM, schematics, and layout
- Reference application with C source code

Software Development Kit (SDK)

- Dual OS ThreadX / Linux with patches, drivers, tools, and application source code
- Royalty-free libraries for ISP, 3A, dewarp, and codecs
- Image tuning and manufacturing calibration tools
- Detailed documentation with programmer's manual and application notes

Contact www.ambarella.com/about/contact/inquiries.html

Copyright Ambarella, Inc. All rights reserved. Ambarella, and the Ambarella logo are trademarks of Ambarella, Inc. All other brands, product names and company names are trademarks of their respective owners. The information in this document is believed to be reliable, but may project preliminary functionality not yet available. Ambarella, Inc. makes no guarantee or warranty concerning the accuracy and availability of said information and shall not be responsible for any loss or damage whatever nature resulting from the use of, or reliance upon it. Ambarella, Inc. does not guarantee that the use of any information contained herein will not infringe upon patent, trademark, copyright, or other rights of third parties. Ambarella, Inc. reserves the right to make changes in the product and for its specifications presented in this publication at any time without notice.